

Specification sheet LX 1327

Siphonic Parapet drains Series 62 DRAINJET® without roof penetration

Emergency drainage	
Siphonic flow	
Silent Power	
Discharge rate:	8,5 l/sec
Water height:	75 mm
Roof penetration:	0 mm
Diameter:	DN 50
LX-Number:	LX 1327
Weir height:	60 mm
Drain:	not ventilated
Downpipe:	not ventilated
Downpipe height:	min 4,2 m
Drainage:	on floor

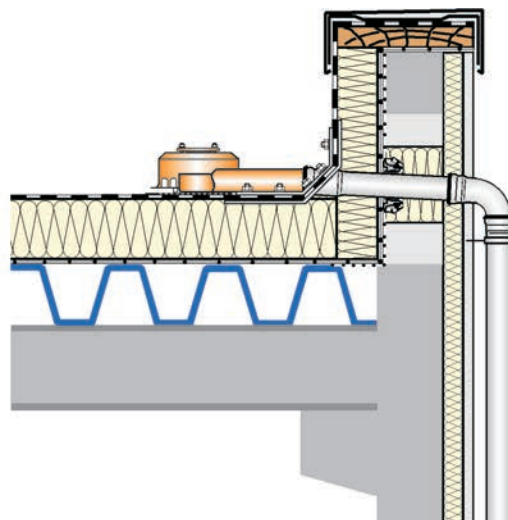

LX 1327 Piece list

- 1 x Art.-No. choose drain on page two!
- 1 x Art.-No. 01401.050X, LORO-X Pipe with one socket
- 1 x Art.-No. 13232.050X, LORO-Sliding flange
- 1 x Art.-No. 00350.050X, LORO-X Bend
- 1 x Art.-No. 01011.050X, LORO-X Pipe with one socket
- 1 x Art.-No. 00320.050X, LORO-X Bend

- 4 x Art.-No. 00911.050X, LORO-X Sealing elements
- 2 x Art.-No. 00973.050X, LORO-X Pipe clamps
- 1 x Art.-No. 00986.000X, LORO-X Lubricant
- 3 x Art.-No. 00806.050X, LORO-X Anchor clips
- 2 x Art.-No. 09603.200X, LORO-X Threaded rods

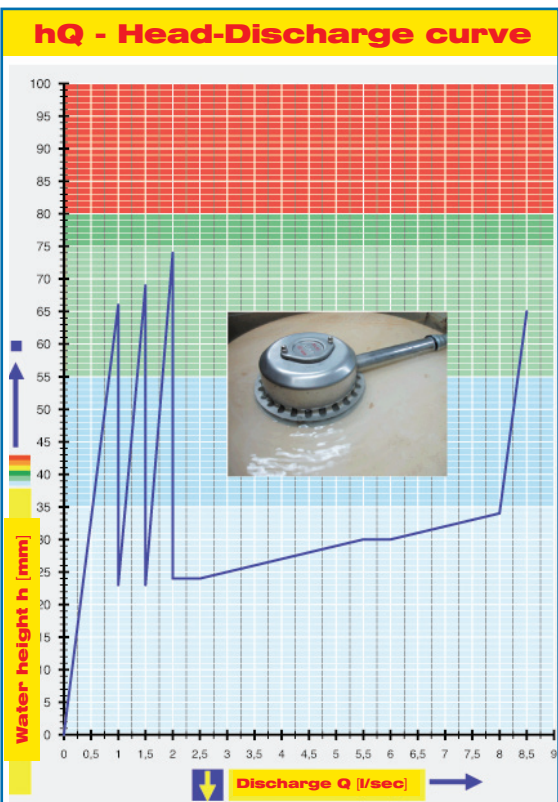

Systempower

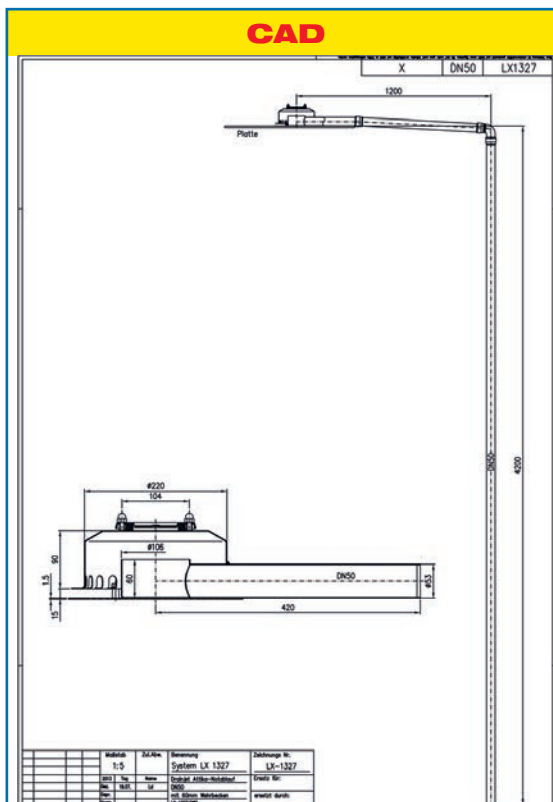

Systemshape

Water height	mm	5	10	15	20	25	30	35	40	45	50	55	60	65	70	75	
Discharge	l/sec															8,5	
		Silent						Silent Power									

Choose drain for piece list on page one!

LX1327-1X

Drain Art.-No. 01375.050X

clamping flange 90°
for plastic roofing sheets
Weir height 60 mm

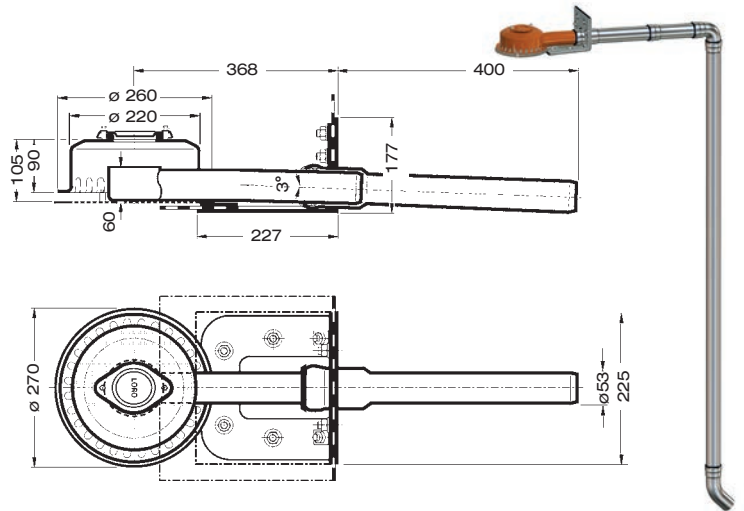

LX1327-2X

Drain Art.-No. 01359.050X

clamping flange 45°
for bituminous roofing sheets
Weir height 60 mm

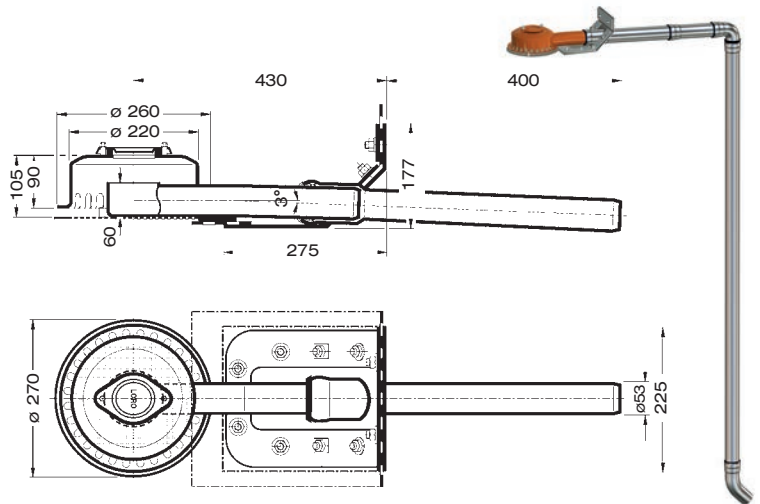

LX1327-3X

Drain Art.-NO. 01387.050X

bonding flange 45°
for bituminous roofing sheets
Weir height 60 mm

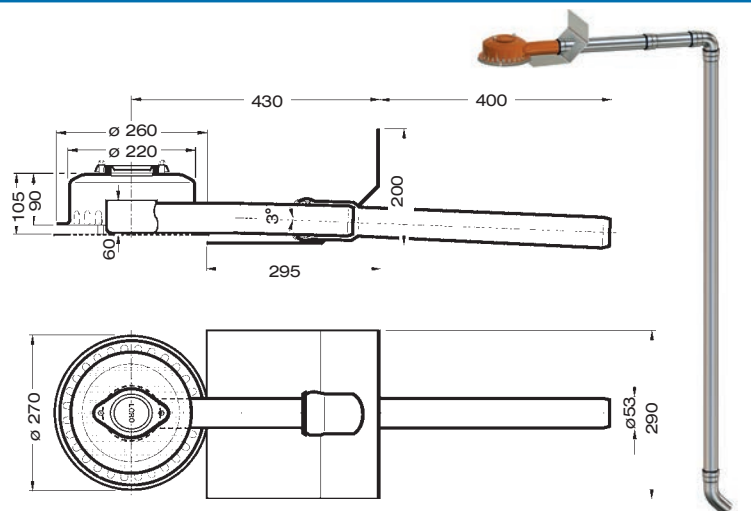

Please note:

For drainage systems with siphonic flow it is vital that only LORO-X pipes and fittings in the combination as indicated are used. Mixture or exchange of system parts may result in lower discharge capacities! The height of the downpipe must be a min. 4.2m for the indicated capacity to be obtained. If roof drain and downpipe are fitted by different crews, then do follow the system setup acc. to the LX-data sheet at www.loro-x.com

Heat tracing: Lorowerk recommends to check all drains and pipes with regard to their frost-sensibility. Where necessary, these parts should be upgraded with heat tracing.